



Dynapac CA2500D

Single drum vibratory rollers





Technical data

 Masses	
Operating mass (incl. ROPS)	22,300 lbs
Operating mass (incl. Cab)	22,700 lbs
Module mass (front, std/rear)	5,600/4,700 kg
Max. operating mass	26,200 lbs

 Dimensions	
Drum width	84 in

 Propulsion	
Speed range	0 -5 mph
Tire size (8 ply)	23,1 x 26 AW
Theor. gradeability	51 %
Vertical oscillation	±9°

 Compaction	
Static linear load	146 lbs/in
Nominal amplitude (high/low)	0.071 in/0.035 in
Vibration frequency (high/low amplitude)	1,980 vpm/2,040 vpm
Centrifugal force (high/low amplitude)	56,210 lb/29,230 lb

 Engine	
Manufacturer/Model	Cummins QSF3.8 (IV/4final)
Type	Water cooled turbo Diesel
Rated power, SAE J1995	89 kW (120 hp) @ 2,200 rpm
Fuel tank capacity	72 gal
DEF tank capacity	5 gal

 Engine	
Manufacturer/Model	Cummins QSB4.5 (IIIA/3)
Type	Water cooled turbo Diesel
Rated power, SAE J1995	97 kW (130 hp) @ 2,200 rpm

 Hydraulic system	
Driving	Hydrostatic
Vibration	Hydrostatic
Steering	Hydrostatic
Service brake	Hydrostatic in forward and reverse lever.
Parking/Emergency brake	Failsafe multidisc brake in drum gear box and in rear axle.

Find us locally at www.dynapac.us

We reserve the right to change specifications without notice. Photos and illustrations do not always show standard versions of machines. The above information is a general description only, all informations are supplied without liability.

Dynapac CA2500D

Single drum vibratory rollers



Technical data

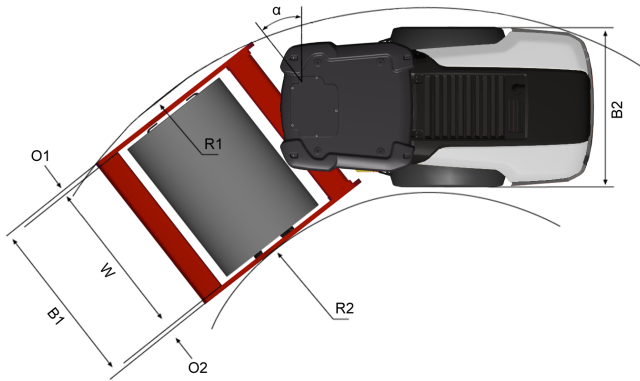
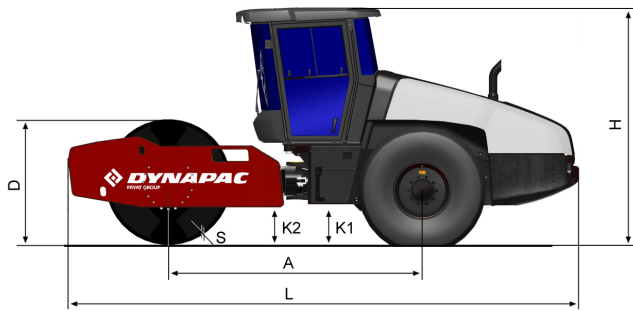

Dimensions	
A. Wheelbase	118 in
B1. Width, front	91 in
B2. Width, rear	84 in
D. Drum diameter	59 in
H. Height, with ROPS/cab	113 in
K1. Ground clearance	18 in
K2. Curb clearance	18 in
L. Length	236 in
O1. Overhang, right	4 in
O2. Overhang, left	4 in
R1. Turning radius, outside	215 in
R2. Turning radius, inside	130 in
S. Drum shell thickness	1 in
W. Drum width	84 in
α. Steering angle	±38°



Standard equipment

- 24V outlet socket, operator's platform
- Automatic vibration control
- Back up alarm
- Brake release
- Cross Mounted Engine
- Combi cooler with Hydraulically driven fan
- Display: Engine temp, Fuel level, Hydr. temp, Speedometer, Tachometer, Voltage
- Dual speed drum drive motor
- Emergency stop
- Filler cap inside lockable hood
- Hydraulic checkpoints
- Parking brake
- Shock mounted platform
- Steering wheel, adjustable
- Suspension seat, swivelling
- Storage Compartment
- Vandal cover
- Warning lights: Air cleaner, Brake, Clogged hyd. fluid filter, Engine oil pressure/temp, Hyd oil temp, Low charge, Low fuel
- 1m X 1m Visibility
- Zero spill oil & coolant change

Find us locally at www.dynapac.us

We reserve the right to change specifications without notice. Photos and illustrations do not always show standard versions of machines. The above information is a general description only, all informations are supplied without liability.