



## COMPACT 2668 RT COMPACT 3368 RT

### Outstanding rough terrain driving features

- 4 wheel drive
- Automatic differential lock
- Excellent gradeability of 40%
- Ground clearance of 11 in

### Durable and easy to maintain

- Outriggers positioned within the machine footprint
- Durable and reliable upper control box
- Optimized accessibility to components
- Built-in diagnostic tool

### Exceptional productivity

- Fully proportional controls
- Tight turning radius
- One switch to deploy and retract all 4 outriggers



**Haulotte**   
GROUP

More than lifting



# COMPACT 2668/3368 RT

ROUGH TERRAIN SCISSOR LIFTS



## TECHNICAL DATA

### COMPACT 2668 RT COMPACT 3368 RT

Working height	33 ft 2 in	39 ft
Platform height	27 ft 2 in	33 ft 0 in
Lift capacity	1250 lbs	1000 lbs
<b>A</b> Length	10 ft 5 in	10 ft 5 in
<b>B</b> Width	5 ft 10 in	5 ft 10 in
<b>C</b> Height - stowed	8 ft	8 ft 5 in
Storage height	5 ft 3 in	5 ft 2 in
<b>F</b> Platform length	8 ft	8 ft
Extended platform length	12 ft 2 in	12 ft 2 in
Platform extension length	3 ft 11 in	3 ft 11 in
<b>G</b> Platform width	4 ft 9 in	4 ft 9 in
<b>D</b> Wheelbase	6 ft 0 in	6 ft
<b>E</b> Ground clearance	11 in	11 in
Number of extensions	1	1
Drive speed	0.5 - 3.4 mph	0.5 - 3.4 mph
Turning radius - outside	11 ft 6 in	11 ft 6 in
Lift / lower speed	35 s / 46 s	40 s / 51 s
Engine	18.5 kW - 24.8 hp	18.5 kW - 24.8 hp
Gradeability	40 %	40 %
Tires	26x12-16.5	26x12-16.5
Hydraulic tank capacity	20 gal	20 gal
Weight	7,762	9,063

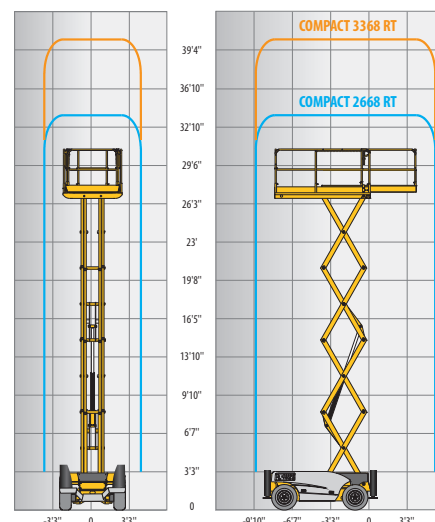
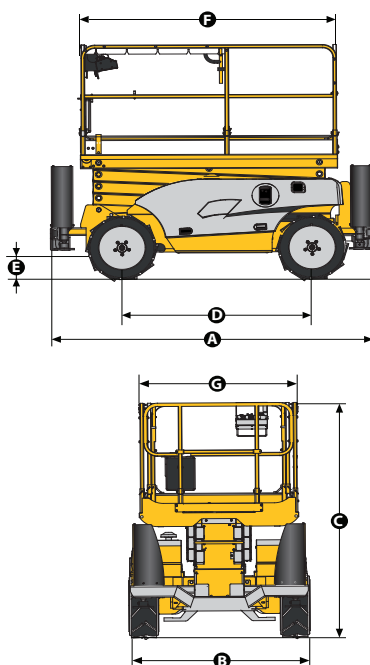

## STANDARD EQUIPMENT

- Kubota engine
- 4 wheel drive, 2 wheel steer
- 5° Tilt alarm
- 3 ft 9 in platform extension
- 12V - 74 Amph Battery
- Removable operator's control box
- Brake release
- Hour meter
- Towing hooks
- Hydraulic brakes
- Manual platform lowering
- Foam filled all terrain tires
- Hydraulic leveling jacks
- Fold down guardrails
- Electronic horn
- Lanyard attachment points

## OPTIONS AND ACCESSORIES

- Non-marking tires
- Flashing beacon
- Power to the platform
- Travel alarm
- Motion alarm (travel and elevate)
- 70 W platform workin light
- Biodegradable oil
- Cold Weather Package
- Swing-door gate
- Folding guardrails
- Hydraulic generator 3.5 kW